

# THE SIZE OF CHARACTERS OF EXCEPTIONAL LIE GROUPS

KATHRYN E. HARE and KAREN YEATS

(Received 1 October 2002; revised 21 July 2003)

Communicated by A. H. Dooley

## Abstract

Pointwise bounds for characters of representations of the compact, connected, simple, exceptional Lie groups are obtained. It is a classical result that if  $\mu$  is a central, continuous measure on such a group, then  $\mu^{\dim G}$  is absolutely continuous. Our estimates on the size of characters allow us to prove that the exponent, dimension of  $G$ , can be replaced by approximately the rank of  $G$ . Similar results were obtained earlier for the classical, compact Lie groups.

2000 *Mathematics subject classification*: primary 22E46; secondary 43A80, 43A65.

*Keywords and phrases*: compact, exceptional Lie group, characters, central measures.

## 1. Introduction

In 1972, Ragozin [7] proved the striking fact that if  $G$  was any compact, connected, simple Lie group and  $\mu$  was a central, continuous measure on  $G$ , then  $\mu^{\dim G} \in L^1(G)$  (the product here being convolution). One consequence of this result is that it implies that if  $g$  is not in the centre of the group, then  $\text{Tr } \lambda(g) / \text{deg } \lambda \rightarrow 0$  as the degree of the representation  $\lambda$  tends to infinity (see [10]). Ragozin's result was first improved by one of the authors in [2] where it was shown that if  $g$  was not in the centre of the group, then

$$\left| \frac{\text{Tr } \lambda(g)}{\text{deg } \lambda} \right| \leq c(g) (\text{deg } \lambda)^{-2/(\dim G - \text{rank } G)}$$

and that if  $k > \dim G/2$  and  $\mu$  was any central, continuous measure, then  $\mu^k \in L^1(G)$ .

In [3] sharp estimates on the rate of decay of  $\text{Tr } \lambda(g) / \text{deg } \lambda$  were found for the classical Lie groups. The precise rate depends on the Lie group type, but in each

---

This research was supported in part by NSERC.

case the sharp exponent in the formula above is  $-O(1/\text{rank } G)$ . This result implies that  $\mu^k \in L^1(G)$  for all central, continuous measures  $\mu$  provided  $k$  is approximately  $\text{rank } G$ .

In this paper we obtain similar estimates for the exceptional Lie groups. To be precise, we obtain the following result:

**THEOREM 1.1.** *Suppose  $G$  is one of the five compact, exceptional Lie groups  $G_2, F_4, E_6, E_7$  or  $E_8$ . For every  $g$  not in the centre of  $G$ , there is a constant  $c(g)$  such that*

$$\left| \frac{\text{Tr } \lambda(g)}{\text{deg } \lambda} \right| \leq c(g) (\text{deg } \lambda)^{-s}$$

for all representations  $\lambda$ , provided

$$s \leq \begin{cases} 1/(n-1) & \text{if } G = E_n, n = 6, 7, 8; \\ 1/5 & \text{if } G = F_4; \\ 2/5 & \text{if } G = G_2. \end{cases}$$

We have not been able determine if these estimates are sharp, however, we can use them to improve upon Ragozin’s result.

**COROLLARY 1.2.** *If  $\mu$  is any central, continuous measure on one of the compact, exceptional Lie groups  $G$ , then  $\mu^n \in L^1(G)$  if  $G = E_n$  with  $n = 6, 7, 8$ ,  $\mu^6 \in L^1(G)$  if  $G = F_4$  and  $\mu^3 \in L^1(G)$  if  $G = G_2$ .*

To contrast this with Ragozin’s result we recall that the dimensions of the exceptional groups are:

Type	$G_2$	$F_4$	$E_6$	$E_7$	$E_8$
Dimension	14	52	78	133	248.

In Section 2 of this paper we explain our notation. Section 3 is devoted to proving the theorem for  $E_8$ . In Section 4 we give the proofs for the groups  $E_6, E_7, F_4$  and  $G_2$ . The corollary and applications are discussed in Section 5.

## 2. Notation

Let  $G$  be a compact, connected, simple Lie group and let  $W$  be its Weyl group. The positive roots associated with the base of simple roots  $\Delta$  will be denoted by  $\Phi^+$ ,  $T$  will denote the torus associated with  $\Phi$ , the fundamental dominant weights relative to  $\Delta$  will be denoted by  $\lambda_1, \dots, \lambda_n$ , and  $\Lambda^+$  will be the set of all dominant weights. The

set  $\Lambda^+$  is in a 1-1 correspondence with the dual object  $\widehat{G}$ ;  $\sigma_\lambda \in \widehat{G}$  is indexed by its highest weight  $\lambda \in \Lambda^+$ . The degree of  $\sigma_\lambda$  will be denoted by  $d_\lambda$ . We set  $\rho = \sum_{j=1}^n \lambda_j$ . According to the Weyl dimension formula [11] the degree of  $\lambda$  is given by

$$(2.1) \quad d_\lambda = \prod_{\alpha \in \Phi^+} (\rho + \lambda, \alpha) / (\rho, \alpha).$$

For general facts about root systems we refer the reader to [4].

Given  $g \in T$  we let  $\Phi(g) = \{\alpha \in \Phi : \alpha(g) \in 2\pi\mathbb{Z}\}$  and let  $\Phi^+(g) = \Phi(g) \cap \Phi^+$ . It is easily seen that  $\Phi(g)$  is a subroot system of  $\Phi$  and that  $\Phi^+(g)$  is a complete set of positive roots of this subroot system. It is known that  $\Phi(g) = \Phi$  if and only if  $g$  is in the centre of the group ([1, page 189]).

For  $g$  in the torus, the Weyl character formula ([11]) states

$$\text{Tr } \lambda(g) = \frac{e^{i\rho(g)} \sum_{w \in W} \det w \exp i(\rho + \lambda, w(g))}{\prod_{\alpha \in \Phi^+} (e^{i\alpha(g)} - 1)}.$$

This determines  $\text{Tr } \lambda$  on  $G$  as characters are class functions.

When  $g$  belongs to the centre of the group an application of Schur's lemma shows that  $|\text{Tr } \lambda(g)| = d_\lambda$ , hence the interest is in non-central elements. It was shown in [2] how one can evaluate the Weyl character formula (by considering suitable directional derivatives if  $\Phi^+(g)$  is not empty) to obtain

$$(2.2) \quad \frac{|\text{Tr } \lambda(g)|}{d_\lambda} = c(g) \frac{|\sum_{w \in W} \det w \prod_{\alpha \in \Phi^+(g)} (\rho + \lambda, w(\alpha)) \exp i(\rho + \lambda, w(g))|}{\prod_{\alpha \in \Phi^+} (\rho + \lambda, \alpha)}.$$

Consequently, if one can prove

$$(2.3) \quad \sup_{w \in W} \frac{|\prod_{\alpha \in \Phi^+(g)} (\rho + \lambda, w(\alpha))|}{\prod_{\alpha \in \Phi^+} (\rho + \lambda, \alpha)^{1-s}}$$

is bounded over all  $\lambda$ , then

$$\frac{|\text{Tr } \lambda(g)|}{d_\lambda} \leq \frac{c(g)}{d_\lambda^s}.$$

Thus in order to find pointwise bounds on the trace functions off the centre of  $G$  it is useful to understand the structures of the subroot systems properly contained in  $\Phi$  and how they are affected by the action of the Weyl group. This was the approach (successfully) undertaken in [3] for the classical groups.

In this paper we are interested in the exceptional Lie groups  $G_2, F_4, E_6, E_7$  and  $E_8$ . The root systems and bases we take follow the convention of Humphreys [5] and are summarized below for the convenience of the reader. Note that in type  $G_2$  we

TABLE 1. The exceptional Lie groups  $G_2, F_4, E_6, E_7$  and  $E_8$ .

Type	Root system $\Phi$	Base $\Delta$
$G_2$	$\pm(e_i - e_j),$ $\pm(2e_i - e_j - e_k) : i \neq j \neq k \in \{1, 2, 3\}$	$\alpha_1 = e_1 - e_2,$ $\alpha_2 = -2e_1 + e_2 + e_3$
$F_4$	$\pm e_i \pm e_j, \pm e_i : 1 \leq i \neq j \leq 4$ $\frac{1}{2}(\pm e_1 \pm e_2 \pm e_3 \pm e_4)$	$\alpha_1 = e_2 - e_3, \alpha_2 = e_3 - e_4,$ $\alpha_3 = e_4,$ $\alpha_4 = \frac{1}{2}(e_1 - e_2 - e_3 - e_4)$
$E_8$	$\pm e_i \pm e_j : 1 \leq i < j \leq 8,$ $\frac{1}{2} \sum_{k=1}^8 \pm e_k : \# \text{ minus signs even}$	$\alpha_1 = \frac{1}{2}(e_1 - e_2 - \dots - e_7 + e_8),$ $\alpha_2 = e_1 + e_2,$ $\alpha_i = e_{i-1} - e_{i-2} : 3 \leq i \leq 8$
$E_7$	$\pm e_i \pm e_j : 1 \leq i < j \leq 6,$ $\pm(e_7 - e_8),$ $\pm \frac{1}{2}(e_7 - e_8 + \sum_{k=1}^6 \pm e_k) :$ # minus signs in sum odd	$\alpha_i, i = 1, \dots, 7$ from $E_8$
$E_6$	$\pm e_i \pm e_j : 1 \leq i < j \leq 5,$ $\pm \frac{1}{2}(e_8 - e_7 - e_6 + \sum_{k=1}^5 \pm e_k) :$ # minus signs in sum even	$\alpha_i, i = 1, \dots, 6$ from $E_8$

let  $e_1, e_2, e_3$  denote the standard basis vectors in  $\mathbb{R}^3$ , in  $F_4$  we denote by  $e_1, e_2, e_3, e_4$  the standard basis vectors in  $\mathbb{R}^4$ , and in types  $E_6, E_7, E_8$ , the vectors  $e_i, i = 1, \dots, 8$  denote the standard basis vectors in  $\mathbb{R}^8$  (see Table 1).

It clearly suffices to analyze those subroot systems which are maximal in the sense that there is no other proper subroot system containing that system. Thus it suffices to show that

$$(2.4) \quad \frac{\prod_{\alpha \in \Phi^{+'}}(\rho + \lambda, \alpha)}{\prod_{\alpha \in \Phi^+}(\rho + \lambda, \alpha)^{1-s}} = \prod_{\alpha \in \Phi^{+'}}(\rho + \lambda, \alpha)^s \prod_{\alpha \in \Phi^+ \setminus \Phi^{+'}}(\rho + \lambda, \alpha)^{s-1}$$

is uniformly bounded over  $\lambda$  for  $\Phi^{+'}$  any maximal positive subroot system. The diagrams of these subroot systems are subdiagrams of the extended diagram of the original root system. The extended diagrams can be found in the appendix. Note that the additional vertex, labelled 0, is identified with the highest root  $\alpha_0$  which is equal to  $e_1 + e_2 - 2e_3$  in  $G_2, e_1 + e_2$  in  $F_4, e_7 + e_8$  in  $E_8, e_7 - e_8$  in  $E_7$  and  $\frac{1}{2}(\sum_{i=1}^5 e_i - e_6 - e_7 + e_8)$  in  $E_6$ .

### 3. Proof of Theorem 1.1 for the group $E_8$

The technique used in [3] to estimate the size of the characters of the classical groups involved finding the positive roots associated with maximal subroot systems by considering the Weyl conjugates of the (standard) bases corresponding to subdiagrams

of the extended diagrams. This method does not appear to work well with these exceptional groups because their Weyl groups are very cumbersome and so a different approach seems needed.

We will begin with  $E_8$  as this is the most difficult case. The maximal proper subroot systems are of types  $A_8, A_1 \times A_7, A_1 \times A_2 \times A_5, A_4 \times A_4, D_5 \times A_3, E_6 \times A_2, D_8$  and  $E_7 \times A_1$  with 36, 29, 19, 20, 26, 39, 56 and 64 positive roots, respectively.

Our approach will be to consider the set of roots  $\beta$  such that  $(\lambda_i, \beta) \neq 0$  for the fundamental dominant weights  $\lambda_i, i = 1, \dots, 8$ , and to show that a suitable selection of these do not belong to any maximal positive subroot system  $\Phi^{+'}$ . It is useful to express the fundamental dominant weights  $\lambda_i$  in terms of the standard basis vectors  $e_i$  of  $\mathbb{R}^8$ :

$$\begin{aligned} \lambda_1 &= 2e_8, & \lambda_4 &= e_3 + e_4 + e_5 + e_6 + e_7 + 5e_8, \\ \lambda_2 &= \frac{5}{2}e_8 + \frac{1}{2} \sum_{i=1}^7 e_i, & \lambda_5 &= e_4 + e_5 + e_6 + e_7 + 4e_8, \\ \lambda_3 &= \frac{7}{2}e_8 + \frac{1}{2} \left( \sum_{i=2}^7 e_i - e_1 \right), & \lambda_6 &= e_5 + e_6 + e_7 + 3e_8, \\ & & \lambda_7 &= e_6 + e_7 + 2e_8, \\ & & \lambda_8 &= e_7 + e_8. \end{aligned}$$

Any representation  $\lambda$  can be written as  $\sum_{i=1}^8 m_i \lambda_i$  for non-negative integers  $m_i$ ; we will assume  $m_k = \max_i m_i$ .

Let  $S \subseteq \Phi^+$  be the set of elements  $\beta$  for which  $(\lambda_i, \beta) \neq 0$  for all  $i = 1, \dots, 8$ . It consists of 44 elements:

$$S = \left\{ e_8 \pm e_j : 1 \leq j \leq 6; e_8 + e_7; \frac{1}{2} \left( e_8 + e_7 + \sum_{k=1}^6 \pm e_k \right) \right\}$$

where the roots  $\frac{1}{2}(e_8 + e_7 + \sum_{k=1}^6 \pm e_k)$  have an even number of minus signs. Let  $S_8$  be the set of positive roots  $\beta$  for which  $(\lambda_8, \beta) \neq 0$  and let  $S_0$  be the set of positive roots for which  $(\lambda_i, \beta) \neq 0$  for all  $i = 1, \dots, 7$ . Notice that  $S_8$  contains  $S$  as well as the elements

$$\left\{ \frac{1}{2} \left( e_8 + e_7 - \sum_{i=1}^6 e_i \right), e_7 \pm e_i : i = 1, \dots, 6 \right\},$$

and hence has cardinality at least 57. The set  $S_0$  contains  $S$  and the elements

$$\frac{1}{2} \left( e_8 - e_7 + e_6 + \sum_{i=1}^5 \pm e_i \right),$$

where there are either one or three minus signs in the sum and therefore has at least 59 elements. If  $\Phi^{+'}$  is any of the maximal positive subroot systems other than  $D_8$  or

$E_7 \times A_1$ , then the cardinality of  $\Phi^{+'}$  is at most 39 and hence there must be at least 18 positive roots in  $S_i \setminus \Phi^{+'}$ ,  $i = 0, 8$ .

The sets  $S_8$  and  $S_0$  have the feature that there is a constant  $c > 0$  such that if either  $k = 8$  and  $\beta \in S_8$ , or  $k \neq 8$  and  $\beta \in S_0$ , then  $(\rho + \lambda, \beta) \geq cm_k$ . Hence, for any  $s < 1$ ,

$$\prod_{\alpha \in \Phi^+ \setminus \Phi^{+'}} (\rho + \lambda, \alpha)^{s-1} \leq \prod_{\beta \in S_i \setminus \Phi^{+'}} (\rho + \lambda, \beta)^{s-1} \leq O(m_k^{18(s-1)}).$$

As  $(\rho + \lambda, \alpha) \leq O(m_k)$  for any positive root  $\alpha$ , we obtain the estimate

$$\prod_{\alpha \in \Phi^{+'}} (\rho + \lambda, \alpha)^s \prod_{\alpha \in \Phi^+ \setminus \Phi^{+'}} (\rho + \lambda, \alpha)^{s-1} \leq O(m_k^{39s+18(s-1)}),$$

and this is bounded provided  $s \leq 1/4$ .

The two remaining types of proper subroot systems,  $D_8$  and  $E_7 \times A_1$ , seem to be too large to obtain good bounds by such elementary methods. Instead, we will analyze the size of  $(\Phi^+ \setminus \Phi^{+'}) \cap S$  more carefully, taking into account the possible inner products which can arise between elements of  $S$ .

Consider the elements of  $S$ ,

$$x_{ij} = \frac{1}{2} \left( e_8 + e_7 - e_i - e_j + \sum_{\ell=1, \ell \neq i, j}^6 e_\ell \right)$$

and

$$y_{ij} = \frac{1}{2} \left( e_8 + e_7 + e_i + e_j - \sum_{\ell=1, \ell \neq i, j}^6 e_\ell \right)$$

for  $1 \leq i < j \leq 6$ . Put  $S' \equiv S \setminus \{v\}$ , where  $v = e_8 + e_7$ . Notice that  $x_{ij} + y_{ij} = v$  and  $(v, \alpha) = 1$  for all  $\alpha \in S'$ . As inner products of roots are integral valued, the only possible inner products of roots in  $E_8$  can be  $0, \pm 1, \pm 2$ , with the latter occurring only if the two roots coincide or are negatives of one another. It follows from these remarks that for all  $\alpha \in S' \setminus \{x_{ij}, y_{ij}\}$ , either  $(x_{ij}, \alpha) = 0$  and  $(y_{ij}, \alpha) = 1$ , or  $(x_{ij}, \alpha) = 1$  and  $(y_{ij}, \alpha) = 0$ . Also, note  $(x_{ij}, y_{ij}) = -1$ .

We will be able to exploit this property by making use of the observation that two subroot systems of the same type have the same set of inner products, and the set of inner products of their positive roots can differ only by sign. Thus in making arguments which depend only on inner products up to sign (as we will do for the remaining two cases) we need only consider how the elements of a *particular* subroot system of the required type can ‘play the role’ of the elements of  $S'$ . Therefore we may as well assume the subroot system of type  $D_8$  was formed by removing  $\alpha_1$  and so has positive roots  $\{e_i \pm e_j : 1 \leq j < i \leq 8\}$ , and that the subroot system of type  $E_7 \times A_1$  was formed by removing  $\alpha_8$  and so its positive roots are  $e_7 + e_8$  and the

standard set of positive roots for  $E_7$  as described in Section 2. We will let  $\Phi_0^+$  denote these particular positive subroot systems.

Our goal is to find an upper bound for the number of elements of  $\Phi_0^+$  which can play the role of elements in  $S'$ . Since  $S'$  consists of the 15 pairs  $x_{ij}, y_{ij}$  and 13 other elements, if  $\Phi_0^+$  contains more than 28 elements of  $S'$  there must be a pair  $\alpha, \beta \in \Phi_0^+$  taking the role of a pair  $x_{ij}, y_{ij}$ . This means that  $(\alpha, \beta) = \pm 1$  and any other element,  $\tau \in \Phi_0^+$ , playing the role of an element of  $S'$  must have the property that inner product of one of  $\alpha$  or  $\beta$  with  $\tau$  is zero and the other is modulus one. By counting the number of  $\tau \in \Phi_0^+$  which has this property we will obtain an upper bound on the size of  $\Phi_0^+ \cap S'$ .

The following lemma will make it easy to count the number of such  $\tau$ .

**LEMMA 3.1.** *Suppose  $\alpha \neq \pm\beta$  and  $(\alpha, \beta) \neq 0$ . The number of  $\tau$  such that either  $(\alpha, \tau) = \pm 1$  and  $(\beta, \tau) = 0$  or vice versa, is independent of the choice of  $\alpha, \beta$ .*

**PROOF.** Since  $\alpha \neq \pm\beta$  and  $(\alpha, \beta) \neq 0$ , one of  $\alpha \pm \beta = \gamma \in \Phi'$  (the choice of  $\pm$  depends on the sign of  $(\alpha, \beta)$ ). Similar arguments to those used above show that a positive root  $\tau$  has the property that either  $(\alpha, \tau) = \pm 1$  and  $(\beta, \tau) = 0$  or vice versa if and only if  $(\gamma, \tau) = \pm 1$  and  $\tau \neq \alpha, \beta$ . Thus the number of  $\tau$  having the required property is equal to

$$\sum_{\tau \in \Phi_0^+} |(\gamma, \tau)| - |(\gamma, \gamma)| - |(\gamma, \alpha)| - |(\gamma, \beta)| = \sum_{\tau \in \Phi_0^+} |(\gamma, \tau)| - 4.$$

If  $\alpha', \beta'$  is any other such pair with  $\alpha' \pm \beta' = \gamma'$ , then, of course, the number of  $\tau$  such that either  $(\alpha, \tau) = \pm 1$  and  $(\alpha, \beta') = 0$  or vice versa is equal to  $\sum_{\tau \in \Phi_0^+} |(\gamma', \tau)| - 4$ . As the roots are all the same length, the Weyl group is transitive on  $\Phi_0^+$ , thus

$$\sum_{\tau \in \Phi_0^+} |(\gamma, \tau)| = \sum_{\tau \in \Phi_0^+} |(\gamma', \tau)|,$$

and therefore the number of such  $\tau$  is constant over all these pairs. □

So it suffices to consider one choice of pair. For  $E_7$  it is convenient to choose  $\alpha = \frac{1}{2}(e_8 - e_7 - e_i + \sum_{\ell=1, \ell \neq i}^6 e_\ell)$  and  $\beta = \frac{1}{2}(e_8 - e_7 + e_i - \sum_{\ell=1, \ell \neq i}^6 e_\ell)$ . Then  $\gamma = \alpha + \beta = e_8 - e_7$ . It is easy to check that  $(\gamma, e_i \pm e_j) = 0$  if  $1 \leq j < i \leq 6$ ,  $(\gamma, \gamma) = 2$  and  $(\gamma, \tau) = 1$  for the remaining 32 elements in the positive root system of  $E_7$ . Hence the number of such  $\tau$  is 30, showing that there are at most 32 elements of  $S'$  among the positive roots of  $E_7$  (these 30 and the pair  $\alpha, \beta$ ). As the positive root of  $A_1$  is orthogonal to every element of  $E_7$  it cannot belong to  $S$ , and therefore there can be at most 33 of the positive roots in  $E_7 \times A_1$  contained in  $S$ .

For  $D_8$  choose  $\alpha = e_1 - e_2$ ,  $\beta = e_2 - e_3$  and  $\gamma = e_1 - e_3$ . Then  $(\gamma, \tau) = \pm 1$  if and only if  $\tau = e_1 \pm e_j$ ,  $j \neq 1, 3$ , or  $e_j \pm e_3$ ,  $j \neq 1, 3$  (where in either case we mean the positive root) or  $\tau = \gamma$ . Consequently,  $\sum_{\tau \in \Phi^{+'}} |(\gamma, \tau)| - 4 = 22$ . Thus if there is a pair playing the role of  $x_{ij}$ ,  $y_{ij}$ , then there can be at most 24 elements in  $\Phi_0^+ \cap S'$  and otherwise there can be at most 28 elements.

In all cases, it follows that there must be at least 11 elements of  $S$  not in the positive subroot system, thus we can conclude that

$$\prod_{\alpha \in \Phi^{+'}} (\rho + \lambda, \alpha)^s \prod_{\alpha \in \Phi^+ \setminus \Phi^{+'}} (\rho + \lambda, \alpha)^{s-1} \leq O(m_k^{64s+11(s-1)}).$$

This is bounded if  $s \leq 1/7$ , completing the proof of the theorem for type  $E_8$ .

### 4. The other exceptional groups

**4.1. Proof of Theorem 1.1 for  $E_6$**  For  $E_6$  and  $E_7$  we have not been able to find a suitable pattern in the inner product table which we could exploit. Instead, we will use the fact the definition of  $\Phi(g)$  ensures that any integral linear combination of roots of  $\Phi(g)$ , which is also a root, must belong to  $\Phi(g)$ . In particular, this implies that if the set of roots generated by some subset (under integral linear combinations) is larger than the given proper subroot system  $\Phi(g)$ , then the set itself cannot be completely contained in  $\Phi(g)$ . By applying this argument to the subsets  $S_i = \{\beta \in \Phi^+ : (\lambda_i, \beta) \neq 0\}$ , where  $\lambda_i$ ,  $i = 1, \dots, 6$  denote the fundamental dominant weights we will again be able to argue that a suitable number of elements of  $S_i$  are not in  $\Phi^+(g)$  and thus bound (2.4).

We recall that the fundamental dominant weights can be expressed in terms of the  $e_j$  as follows:

$$\begin{aligned} \lambda_1 &= \frac{2}{3}(e_8 - e_7 - e_6), & \lambda_4 &= e_8 - e_7 - e_6 + e_3 + e_4 + e_5, \\ \lambda_2 &= \frac{1}{2}(e_8 - e_7 - e_6) + \frac{1}{2} \sum_{i=1}^5 e_i, & \lambda_5 &= \frac{2}{3}(e_8 - e_7 - e_6) + e_4 + e_5, \\ \lambda_3 &= \frac{5}{6}(e_8 - e_7 - e_6) - \frac{1}{2}e_1 + \frac{1}{2} \sum_{i=2}^5 e_i, & \lambda_6 &= \frac{1}{3}(e_8 - e_7 - e_6) + e_5. \end{aligned}$$

Put also

$$\begin{aligned} S &= \{\beta \in \Phi^+ : (\lambda_i, \beta) \neq 0 \text{ for } 1 \leq i \leq 6\} \\ &= \left\{ \frac{1}{2} \left( e_8 - e_7 - e_6 + e_5 + \sum_{i=1}^4 \pm e_i \right) : 0 \text{ or } 2 \text{ minus signs in sum} \right\}. \end{aligned}$$



The sets  $S_i$  can be described as follows:

$$S_1 \setminus S = \left\{ \frac{1}{2} \left( e_8 - e_7 - e_6 + e_5 - \sum_{i=1}^4 e_i \right), \right. \\ \left. \frac{1}{2} \left( e_8 - e_7 - e_6 - e_5 + \sum_{k=1}^4 \pm e_k \right) : 1 \text{ or } 3 \text{ minus signs} \right\};$$

$$S_2 \setminus S = \left\{ e_i + e_j : 1 \leq j < i \leq 5; \right. \\ \left. \frac{1}{2} \left( e_8 - e_7 - e_6 - e_5 + \sum_{k=1}^4 \pm e_k \right) : 1 \text{ minus sign} \right\};$$

$$S_3 \setminus S = \left\{ e_i + e_j, e_k - e_1 : 2 \leq j < i \leq 5, 2 \leq k \leq 5; \right. \\ \frac{1}{2} \left( e_8 - e_7 - e_6 + e_5 - \sum_{i=1}^4 e_i \right), \\ \frac{1}{2} \left( e_8 - e_7 - e_6 - e_5 + \sum_{k=2}^4 \pm e_k - e_1 \right) : 2 \text{ minus signs,} \\ \left. \frac{1}{2} \left( e_8 - e_7 - e_6 - e_5 + \sum_{k=1}^4 \pm e_k \right) : 1 \text{ minus sign} \right\};$$

$$S_4 \setminus S = \left\{ e_i \pm e_j : j = 1, 2, i = 3, 4, 5; e_5 + e_4, e_5 + e_3, e_4 + e_3, \right. \\ \frac{1}{2} \left( e_8 - e_7 - e_6 + e_5 - \sum_{i=1}^4 e_i \right), \frac{1}{2} \left( e_8 - \sum_{i=4}^7 e_i + e_3 - e_2 - e_1 \right), \\ \frac{1}{2} \left( e_8 - \sum_{i=4}^7 e_i + e_3 + e_2 + e_1 \right), \\ \left. \frac{1}{2} \left( e_8 - \sum_{i=5}^7 e_i + e_4 + \sum_{k=1}^3 \pm e_k \right) : 1 \text{ or } 3 \text{ minus signs} \right\};$$

$$S_5 \setminus S = \left\{ e_i \pm e_j : j = 1, 2, 3, i = 4, 5; e_5 + e_4, \right. \\ \frac{1}{2} \left( e_8 - e_7 - e_6 + e_5 - \sum_{i=1}^4 e_i \right), \\ \left. \frac{1}{2} \left( e_8 - \sum_{i=5}^7 e_i + e_4 + \sum_{k=1}^3 \pm e_k \right) : 1 \text{ or } 3 \text{ minus signs} \right\};$$

$$S_6 \setminus S = \left\{ \frac{1}{2} (e_8 - e_7 - e_6 + e_5 - e_4 - e_3 - e_2 - e_1), e_5 \pm e_i : 1 \leq i \leq 4 \right\}.$$

So  $|S| = 7$ ,  $|S_1| = 16$ ,  $|S_2| = 21$ ,  $|S_3| = 25$ ,  $|S_4| = 29$ ,  $|S_5| = 25$  and  $|S_6| = 16$ .

The proper subroot systems in  $E_6$  are of types  $A_5 \times A_1$  with 16 positive roots,  $A_2 \times A_2 \times A_2$  with 9 positive roots and  $D_5$  with 20 positive roots.

If  $\lambda = \sum m_i \lambda_i$  has largest coefficient  $m_k$  and  $k = 3, 4, 5$ , we can use the sets  $S_k$  in the same manner as the easy  $E_8$  cases to obtain the inequality

$$\prod_{\alpha \in \Phi^{+'}} (\rho + \lambda, \alpha)^s \prod_{\alpha \in \Phi^+ \setminus \Phi^{+'}} (\rho + \lambda, \alpha)^{1-s} \leq cm_k^{(20+5)s-5}.$$

This is bounded for  $s \leq 1/5$ .

This leaves three cases,  $k = 1, 2, 6$ , which will be settled by the generating subsets argument briefly outlined above. We will show that in these cases, as well, at least

five elements of  $S_k$  are not in the proper subroot system  $\Phi^+(g)$ , so that the calculation above can still be invoked to show  $s \leq 1/5$  is sufficient.

Roots of the form  $e_i \pm e_j$  we will call standard and the others, peculiar. Observe that any set generated by the standard roots  $\{e_{i_0} + e_j : j \in I\}$  (or  $\{e_{i_0} - e_j : j \in I\}$ ) for some  $i_0 \notin I$ , together with a single root  $e_{i_0} - e_j$  (respectively,  $e_{i_0} + e_j$ ) for some  $j \in I$ , will contain  $\{e_i \pm e_j : i, j \in I \cup \{i_0\}\}$ . We will refer to this set as a standard  $D_n$ , with  $n = |I| + 1$ , on the letters  $I \cup \{i_0\}$  (or, simply, a standard  $D_n$  if it is on the letters  $\{1, 2, \dots, n\}$ ). For example, by considering differences of elements of  $S$  one can readily see that the set generated by  $S$  contains a standard  $D_4$ .

Our strategy will be to show that any subset of  $S_k$ , consisting of all but four of its elements, will generate a standard  $D_5$ . We can assume  $\Phi^+(g)$  also contains at least 3 elements of  $S$  (for otherwise we are done), none of which are in the standard  $D_5$ . This forces  $\Phi^+(g)$  to have at least 23 elements which is impossible as the largest proper positive subroot system of  $E_6$  has only 20 elements.

We consider each  $S_k$  separately.

$S_6$  : If all the peculiar elements of  $S_6$  belong to  $\Phi^+(g)$  (we will say we remove no peculiar elements), then all of  $S$  and at least one element of the form  $e_5 \pm e_i$ ,  $i = 1, \dots, 4$ , must belong to  $\Phi^+(g)$ . This set generates a standard  $D_5$  which, as we remarked above, is not possible.

If we remove no standard elements, then we can generate a standard  $D_5$  by the roots  $\{e_5 \pm e_i : i = 1, \dots, 4\}$ .

Otherwise we remove 1, 2 or 3 peculiar roots. Then we keep either all  $e_5 + e_i$  or all  $e_5 - e_i$  for  $i$  belonging to a three element subset  $I'$  of  $\{1, \dots, 4\}$ , and a root  $e_5 - e_i$  (respectively,  $e_5 + e_i$ ) for one index  $i \in I'$ . These generate a standard  $D_4$  on the letters  $I' \cup \{5\}$ . If  $k$  is the missing index we can find two peculiar elements from among the remainder which differ at this index, and using these we can generate a standard  $D_5$ .

$S_2$  : If we remove at most one peculiar root we keep either all of  $S$  or all of the elements  $\frac{1}{2}(e_8 - e_7 - e_6 - e_5 + \sum_{k=1}^4 \pm e_k)$  with one negative sign in the sum. As well, we keep at least one  $e_i + e_j$  for  $i, j \in \{1, \dots, 4\}$ . By taking differences of these elements we can generate a standard  $D_4$ . As we keep peculiar roots with both  $\pm e_5$ , a standard  $D_5$  can be obtained.

Otherwise, at most two standard roots are removed. Then there must be four roots of the form  $e_i + e_j$ ,  $j \neq i$ , for some fixed  $i$  and at least one other root of the form  $e_j + e_k$ ,  $j, k \neq i$ . But then  $e_i - e_k$  is in the generated set and consequently the set generates a standard  $D_5$ .

$S_1$  : If at most one peculiar root with a  $-e_5$  term is removed, then we are left with either all of the peculiar roots  $\frac{1}{2}(e_8 - e_7 - e_6 - e_5 + \sum_{k=1}^4 \pm e_k)$  with one minus sign in the sum and one with three minus signs, or vice versa. These roots generate a standard  $D_4$ . Since there is also a peculiar root kept with a  $+e_5$  term, we generate a standard  $D_5$ .

If at most one peculiar root with a  $+e_5$  term is removed we are left with (at least) one of  $\frac{1}{2}(e_8 - e_7 - e_6 + e_5 - \sum_{k=1}^4 e_k)$  or  $\frac{1}{2}(e_8 - e_7 - e_6 + \sum_{k=1}^5 e_k)$ . This root, together with those remaining in  $S$  and a peculiar root with a  $-e_5$  term, generate a standard  $D_5$ .

Finally, if we remove two peculiar roots with a  $+e_5$  and two with  $-e_5$ , then from the remaining elements with a  $-e_5$  term we can take either 3 elements with one minus sign in the sum, along with one other element which is negative in the position  $1 \leq i \leq 4$  which none of the first 3 are negative in, or 3 elements with three minus signs in the sum, along with one other element which is positive in the position which none of the first 3 are positive in. These 4 elements generate a standard  $D_4$  and since there is also a peculiar root with a  $+e_5$  term, again we produce a standard  $D_5$ .

**4.2. Proof of Theorem 1.1 for  $E_7$**  A similar argument can be used for  $E_7$ . A simple calculation shows that the fundamental dominant weights are given by

$$\begin{aligned} \lambda_1 &= e_8 - e_7, & \lambda_4 &= 2e_8 - 2e_7 + e_3 + e_4 + e_5 + e_6, \\ \lambda_2 &= e_8 - e_7 + \frac{1}{2} \sum_{i=1}^6 e_i, & \lambda_5 &= \frac{3}{2}(e_8 - e_7) + e_4 + e_5 + e_6, \\ \lambda_3 &= \frac{3}{2}(e_8 - e_7) - \frac{1}{2}e_1 + \frac{1}{2} \sum_{i=2}^6 e_i, & \lambda_6 &= e_8 - e_7 + e_5 + e_6, \\ & & \lambda_7 &= \frac{1}{2}(e_8 - e_7) + e_6. \end{aligned}$$

Let

$$\begin{aligned} S &= \{ \beta \in \Phi^+ : (\lambda_i, \beta) \neq 0 \text{ for } 1 \leq i \leq 7 \} \\ &= \left\{ e_8 - e_7, \frac{1}{2} \left( e_8 - e_7 + e_6 + \sum_{i=1}^5 \pm e_i \right) : 1 \text{ or } 3 \text{ minus signs in sum} \right\} \end{aligned}$$

and let  $S_i = \{ \beta \in \Phi^+ : (\lambda_i, \beta) \neq 0 \}$ . For example,

$$\begin{aligned} S_1 \setminus S &= \left\{ \frac{1}{2} \left( e_8 - e_7 + e_6 - \sum_{i=1}^5 e_i \right), \right. \\ &\quad \left. \frac{1}{2} \left( e_8 - e_7 - e_6 + \sum_{k=1}^5 \pm e_k \right) : \text{even \# minus signs in sum} \right\}; \\ S_7 \setminus S &= \left\{ \frac{1}{2} \left( e_8 - e_7 + e_6 - \sum_{k=1}^5 e_k \right), e_6 \pm e_i : 1 \leq i \leq 5 \right\}. \end{aligned}$$

One can verify that  $|S| = 16$ ,  $|S_1| = 33$ ,  $|S_2| = 42$ ,  $|S_3| = 47$ ,  $|S_4| = 53$ ,  $|S_5| = 54$ ,  $|S_6| = 42$  and  $|S_7| = 27$ . The proper subroot systems in  $E_7$  are of types  $A_7, A_3 \times A_3 \times A_1, A_5 \times A_2, A_1 \times D_6$  and  $E_6$  with 28, 13, 18, 31 and 36 positive roots respectively.

If  $\lambda = \sum m_i \lambda_i$  has largest coefficient  $m_k$  and  $k = 3, 4$  or  $5$  we can use  $S_k$  and the cardinality argument as in the easy  $E_8$  cases to establish that

$$\prod_{\alpha \in \Phi^{+'}} (\rho + \lambda, \alpha)^s \prod_{\alpha \in \Phi^+ \setminus \Phi^{+'}} (\rho + \lambda, \alpha)^{1-s} \leq cm_k^{(36+11)s-11}.$$

This is bounded if  $s \leq 1/5$ .

For the remaining cases,  $k = 1, 2, 6, 7$ , we can show that there must be at least 8 elements of  $S_k$  not in the subroot system  $\Phi^+(g)$  by using the same basic reasoning as in  $E_6$ . This will prove  $s \leq 1/7$  suffices for all cases.

We proceed by contradiction and so assume that at least 9 elements of  $S$  will belong to  $\Phi^+(g)$ . If we can prove there is a standard  $D_6$  in  $\Phi^+(g)$ , then as none of these belong to  $S$  this will imply  $\Phi^+(g)$  contains at least 39 elements and gives the required contradiction.

Any set containing all but three of the elements of  $S$  will generate a standard  $D_5$ . Together with any peculiar element with a  $-e_6$  term, or an element of the form  $e_6 \pm e_i$ , (at least one of which we can find among the elements in  $S_k \cap \Phi^+(g)$ ), a standard  $D_6$  is produced. Consequently, at least four elements of  $S$  must not belong to  $\Phi^+(g)$ .

A similar argument shows that at least four elements from  $S_1 \setminus S$  must not belong to the positive subroot system, thus at least eight elements of  $S_1$  are not in  $\Phi^+(g)$ .

For  $S_7$  we note that any set of all but three elements of  $\{e_6 \pm e_i : i \in \{1, \dots, 5\}\}$  will contain a subset of the form  $e_6 + e'_i$ , where  $e'_i = \pm e_i$  and  $i$  runs over four values out of  $\{1, 2, 3, 4, 5\}$ , as well as an element  $e_6 - e'_j$  for one choice of  $j$  chosen from the values of  $i$ . These five elements generate  $D_5$  on the letter 6 and the four letters taken on by the index  $i$ . By choosing two peculiar elements from  $S_7 \cap \Phi^+(g)$  which differ at the missing index we generate a standard  $D_6$ . This proves 8 elements from  $S_7$  are not contained in the subroot system.

For the cases  $S_2$  and  $S_6$  a simple cardinality argument shows at least 6 elements are not in the subroot system, but similar reasoning to that above will yield the desired improvement.

**4.3. Proof of Theorem 1.1 for  $F_4$**  The same technique can be used for  $F_4$ , as well. Recall that the fundamental dominant weights are  $\lambda_1 = e_1 + e_2$ ,  $\lambda_2 = 2e_1 + e_2 + e_3$ ,  $\lambda_3 = (3e_1 + e_2 + e_3 + e_4)/2$  and  $\lambda_4 = e_1$ . As usual let

$$S = \{\beta \in \Phi^+ : (\lambda_i, \beta) \neq 0 \text{ for } 1 \leq i \leq 4\} \quad \text{and} \quad S_i = \{\beta \in \Phi^+ : (\lambda_i, \beta) \neq 0\}.$$

Their cardinalities are  $|S| = 10$ ,  $|S_1| = 15$ ,  $|S_2| = 20$ ,  $|S_3| = 20$  and  $|S_4| = 15$ .

The maximal proper subroot systems in  $F_4$  are of types  $A_1 \times C_3$ ,  $A_2 \times A_2$ ,  $A_3 \times A_1$  and  $B_4$  with 10, 6, 7 and 16 positive roots respectively. If the set  $S_i$  corresponding to the  $\lambda_i$  with the largest coefficient contains at least four elements that are not in the

subroot system  $\Phi^+(g)$ , then

$$\prod_{\alpha \in \Phi^{+'}} (\rho + \lambda, \alpha)^s \prod_{\alpha \in \Phi^+ \setminus \Phi^{+'}} (\rho + \lambda, \alpha)^{s-1} \leq cm_k^{(16+4)s-4},$$

and this is bounded if  $s \leq 1/5$ . This is clearly the case if the subroot systems are type  $A_1 \times C_3, A_2 \times A_2$  or  $A_3 \times A_1$  (in these cases  $s \leq 1/3$  will actually suffice) or if the system is type  $B_4$  and  $m_k$  is the maximal coefficient of  $\lambda$  with  $k = 2, 3$ .

One can check that any set consisting of all but three of the elements of  $S_k$  will generate a standard  $D_4$ . As these 12 roots are of length  $\sqrt{2}$ , as are the 4 (additional) peculiar roots contained in  $S$ , and  $B_4$  has only 12 roots of length  $\sqrt{2}$ , this shows  $S_k$  must contain at least four elements which are not in  $B_4$ .

**REMARK.** We note that this is the best result that can be obtained using this technique as the standard roots of  $S_1$  all belong to a standard  $B_4$  and there are only four peculiar roots in  $S_1$ .

**4.4. Proof of Theorem 1.1 for  $G_2$**  The arguments for  $G_2$  are very simple. We note that  $\lambda_1 = e_3 - e_2$  and  $\lambda_2 = 2e_3 - e_1 - e_2$ , thus if  $S_i = \{\beta \in \Phi^+ : (\lambda_i, \beta) \neq 0\}$ ,  $i = 1, 2$ , then  $|S_1| = |S_2| = 5$ .

The maximal subroot systems in  $G_2$  have either 2 or 3 positive roots. By simply counting leftover terms in the set  $S_i$  corresponding to the  $\lambda_i$  with the largest coefficient we obtain the desired result.

**REMARK.** In [3] the optimal rate of decay of the characters was determined for the classical Lie groups. One step in establishing this was to prove that

$$\det w \operatorname{sign} \left( \prod_{\alpha \in \Phi^+(g)} (\rho + \lambda, w(\alpha)) \right) \exp i(\rho + \lambda, w(g))$$

was constant over all  $w \in W$ , for an appropriate  $g \in G$  and suitable number of representations  $\lambda$ . We have not been able to determine if this is true with the exceptional groups.

### 5. Smoothness of convolution powers of central measures

A measure  $\mu$  on  $G$  is called *central* if  $\mu$  commutes with all other measures on  $G$  under the action of convolution. Central measures are characterized by the fact that their Fourier transforms are scalar multiples of identity matrices:

$$\widehat{\mu}(\lambda) = a_\lambda I_{d_\lambda} \quad \text{where} \quad a_\lambda = \int_G \frac{\operatorname{Tr} \lambda(x)}{d_\lambda} d\mu.$$

We will simply write  $\widehat{\mu}(\lambda)$  in place of  $a_\lambda$ .

The orbital measure,  $\mu_g$ , supported on the conjugacy class  $C(g)$  containing  $g \in G$ , is defined by

$$\int_G f d\mu_g = \int_G f(tgt^{-1}) dm_G(t) \quad \text{for } f \in C(G).$$

Orbital measures are examples of singular, central measures and are continuous if and only if  $g$  does not belong to the centre of  $G$ . Moreover, they have the property that

$$\widehat{\mu}_g(\lambda) = \frac{\text{Tr } \lambda(g)}{d_\lambda}.$$

In [7] Ragozin proved that if  $\mu$  was any central, continuous measure, then  $\mu^{\dim G} \in L^1(G)$ . By appealing to the sharper estimates of this paper on the rate of decay of the characters we can improve this result.

**PROPOSITION 5.1.** *Suppose  $G$  is one of the compact, exceptional Lie groups and  $\mu_g$  is a central, continuous orbital measure. Then  $\mu_g^k$  belongs to  $L^2(G)$  if  $k \geq k_0$ , where*

$$k_0 = \begin{cases} n & \text{if } G \text{ is type } E_n; \\ 6 & \text{if } G \text{ is type } F_4; \\ 3 & \text{if } G \text{ is type } G_2. \end{cases}$$

**PROOF.** From the Peter-Weyl theorem it is known that  $\mu_g^k \in L^2$  if

$$\sum_{\lambda \in \widehat{G}} d_\lambda |\widehat{\mu}_g(\lambda)|^{2k} \text{Tr } |I_{d_\lambda}|^2 = \sum_{\lambda \in \widehat{G}} d_\lambda^2 \left| \frac{\text{Tr } \lambda(g)}{d_\lambda} \right|^{2k} < \infty.$$

It was shown in [2, Corollary 9] that  $\sum_{\lambda \in \widehat{G}} d_\lambda^t < \infty$  when  $t < -\text{rank } G/|\Phi^+|$ . The proposition follows by combining these facts with the estimates on the rate of decay of the characters given in the theorem. □

**COROLLARY 5.2.** *Suppose  $\mu_1, \dots, \mu_k$  are central continuous measures on one of the compact, exceptional Lie groups  $G$  and  $k \geq k_0$ . Then  $\mu_1 * \dots * \mu_k \in L^1(G)$ .*

**PROOF.** The proof is essentially the same as [2, Theorem 11], but uses the stronger results obtained in the proposition above. □

Note that the corollary stated in the introduction is a special case.

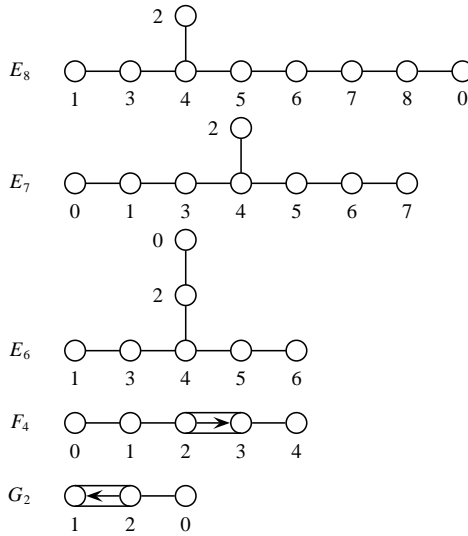

FIGURE 1. Extended Dynkin diagrams

**REMARK.** Ragozin observed that  $\mu_g^k$  is singular to Haar measure on  $G$  for all  $k < \dim G / \dim C(g)$ . As  $\dim C(g) = 2(|\Phi^+| - |\Phi^+(g)|)$  (see [6]) the corollary above can be seen to be sharp for  $G_2$ . This observation also implies that exponent 3 is necessary for  $E_6, E_7$  and  $E_8$ , and exponent 4 is required for  $F_4$ .

**REMARK.** A measure  $\mu$  is called  $L^p$ -improving if there is some  $p < 2$  such that  $\mu * L^p \subseteq L^2$ . A question of current interest is to understand which singular measures on compact groups are  $L^p$ -improving. For example, surface measures on analytic manifolds which generate  $G$  were shown to be  $L^p$ -improving in [8] and in [9] the optimal choice of  $p$  was found for orbital measures  $\mu_g$  with  $\Phi^+(g)$  empty. Sufficient conditions on the size of  $p$  which are valid for all continuous, orbital measures were found for the classical Lie groups in [3]. Similar arguments based on our theorem can be used to obtain results for the exceptional Lie groups.

### References

[1] T. Brocker and T. Dieck, *Representations of compact Lie groups* (Springer, New York, 1985).  
 [2] K. Hare, ‘The size of characters of compact Lie groups’, *Studia Math.* **129** (1998), 1–18.  
 [3] K. Hare, D. Wilson and W. L. Yee, ‘Pointwise estimates of the size of characters of compact Lie groups’, *J. Austral. Math. Soc.* **69** (2000), 61–84.  
 [4] J. Humphreys, *Introduction to Lie algebras and representation theory* (Springer, New York, 1972).

- [5] ———, *Reflection groups and Coxeter groups*, Cambridge Stud. Adv. Math. 29 (Cambridge University Press, Cambridge, 1990).
- [6] M. Mirmura and H. Toda, *Topology of Lie groups*, Transl. Math. Monographs 91 (Amer. Math. Soc., Providence, 1991).
- [7] D. Ragozin, 'Central measures on compact simple Lie groups', *J. Funct. Anal.* **10** (1972), 212–229.
- [8] F. Ricci and E. M. Stein, 'Harmonic analysis on nilpotent groups and singular integrals. III. Fractional integration along manifolds', *J. Funct. Anal.* **86** (1989), 360–389.
- [9] F. Ricci and G. Travaglini, ' $L^p - L^q$  estimates for orbital measures and Radon transform on compact Lie groups and Lie algebras', *J. Funct. Anal.* **129** (1995), 132–147.
- [10] D. Rider, 'Central lacunary sets', *Monatsh. Math.* **76** (1972), 328–338.
- [11] V. Varadarajan, *Lie groups, Lie algebras and their representations* (Springer, New York, 1984).

Department of Pure Mathematics

University of Waterloo

Waterloo, Ont. N2L 3G1

Canada

e-mail: [kehare@uwaterloo.ca](mailto:kehare@uwaterloo.ca)

[kayeats@uwaterloo.ca](mailto:kayeats@uwaterloo.ca)